

Reflow Solder Oven with Vacuum



RSO-300, RSO-300-HV

- For substrate size 309 mm x 319 mm x 40 mm
- Max. Temperature: 650 °C
- Ramp up rate up to 10 K/sec
- SIMATIC® Controller with 7" touch panel
- Vacuum up to 10⁻³ hPa
- Process gas line with Mass Flow Controller for Nitrogen

Application

- Reflow Solder Processes without flux
- Operation with inert gas, Oxygen, Hydrogen, Forming gas, Formic Acid
- Lead and Lead-free SMT reflow
- High temperature ceramic/alumina hybrid reflow
- Pin-in-paste reflow
- Semiconductor
- LED attach

Features

- Precise ramp up and fast ramp down rates
- Up to 4 gas lines
- Heated by Infrared Lamps
- 50 programs with 50 steps each
- Integrated data logging
- Small foot print
- Incl. Quartz glass universal holder and graphite susceptor

RSO-300 similar to RSO-200 with SPS Controller and 7" touch Panel

RSO-300, RSO-300-HV

- Reflow Solder Process Oven with vacuum
- Touch Panel Sivel
- Programmable temperature profiles
- Record of process data
- Process in different gas atmospheres

Application

The RSO-300 Reflow Solder System is an excellent tool for various solder applications up to 309 mm x 319 mm x 40 mm substrate size.

Many reflow soldering applications require an inert process area (oxygenfree) within the reflow oven. The gas used to purge the chamber of oxygen is typically nitrogen. The two advantages of a nitrogen inert reflow process are as follows:

Nitrogen replaces oxygen, and due to its inert (non-reactive) nature, provides greater profile flexibility and widens the process window.

Some examples for applications:

Laboratory furnace for all kind of developers implementing and researching new processes, prototype research, environmental research purposes and for small preseries or series.

Process Gases

The RSO-300 can be used with standard process gases, like Nitrogen, Oxygen and Forming Gas. The chamber is sealed and can easily be cleaned.

Flow Meter

One gas line with Mass Flow Controller (MFC) for Nitrogen (5 nlm) is default, three more gas lines (Option: MFC) are possible.

Vacuum

The system is vacuum capable of up to 10^{-3} hPa. For higher vacuum we offer the model RSO-300-HV.

Heating

The maximal achievable temperature is 650 °C . Key features are precisely controlled fast ramp-up 10 K/sec) and excellent ramp-down rates (depends on temperature and loading).

Temperature Distribution

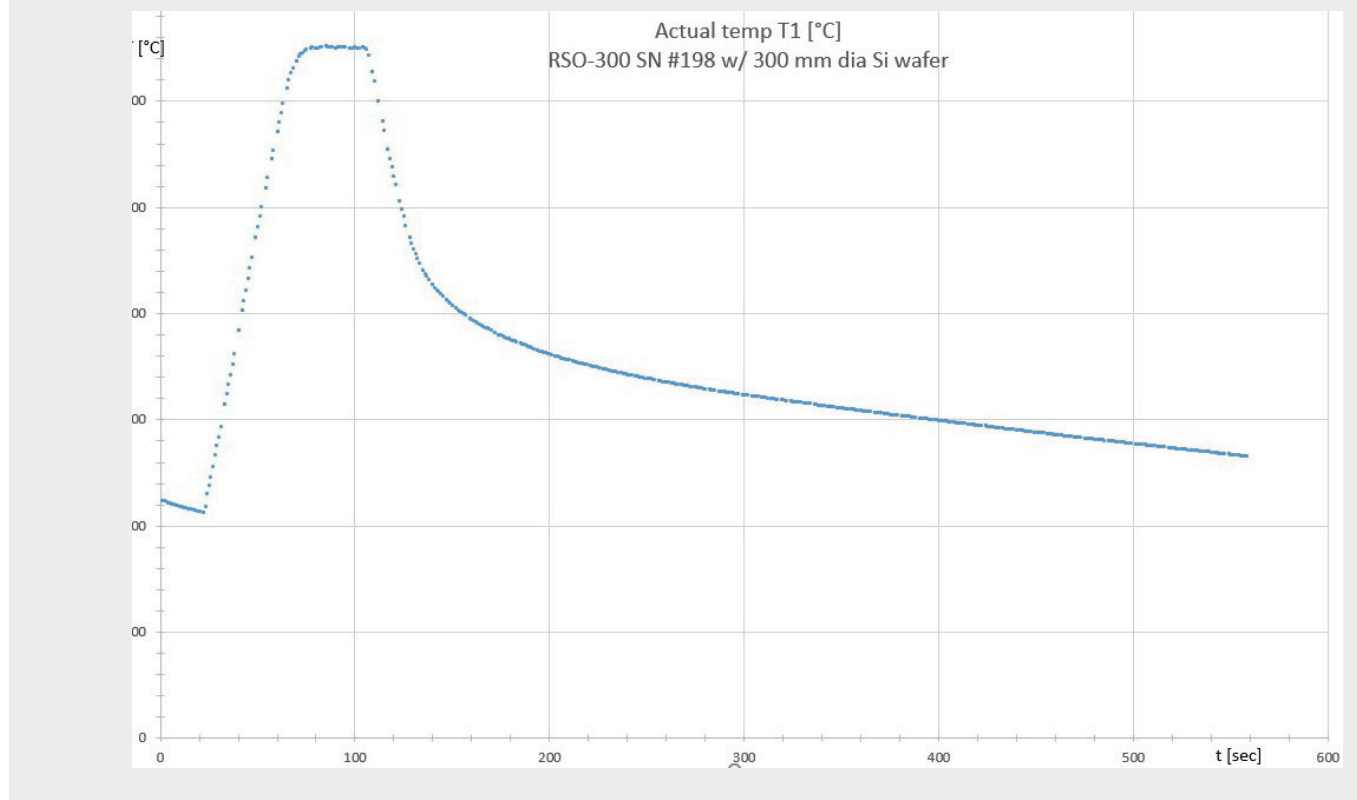

The RSO-300 allows an excellent temperature distribution and homogeneity. A graphite susceptor is included by default (ramp-up rate limited to 10 K/sec).

Programming

The RSO-300 is equipped with a 7" touch panel which allows easy and comfortable programming directly on the unit. 50 programs with 50 steps each can be stored. Unlimited programs can be up- and downloaded from external storage medium.

Process Control

The software allows the permanent monitoring, read-out and analysis of

- temperature
- process gas flow
- cooling water level status
- pressure value and status

Cooling

The cooling of the parts in the quartz chamber is realized by Nitrogen gas which will be led through the chamber. For cooling of the chamber housing cooling we recommend a closed loop water cooling system. (Accessories: WC-II oder WC-III)

Others

An interlock function as well as an Emergency-OFF-Button (EMO) are default.

Special

This oven can also be ordered as „double chamber oven“. By adding a second process chamber (Option: RSO-PC-300) the oven does have 2 process chambers and one controller unit. This saves money when 2 different processes are needed and the chambers shall not be cleaned due to contamination or other reasons.

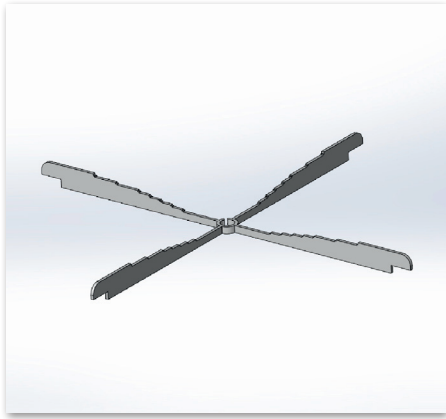

Optional Quartz holder 4-arm

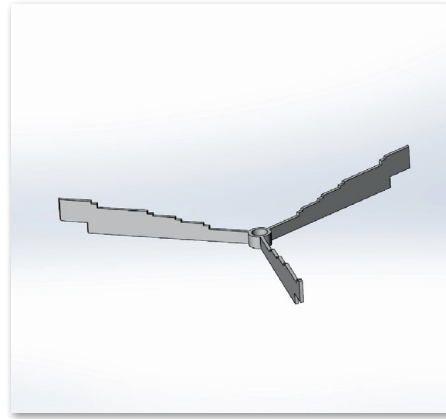

Optional Quartz holder 3-arm

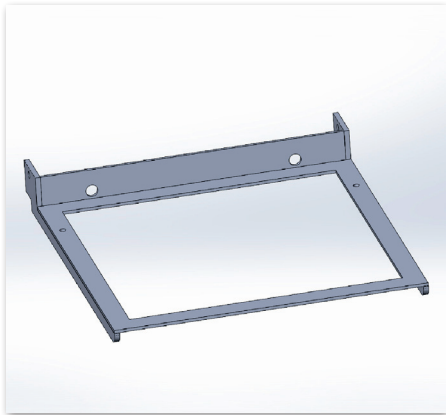

Standard quartz holder (fixed mounted in door)

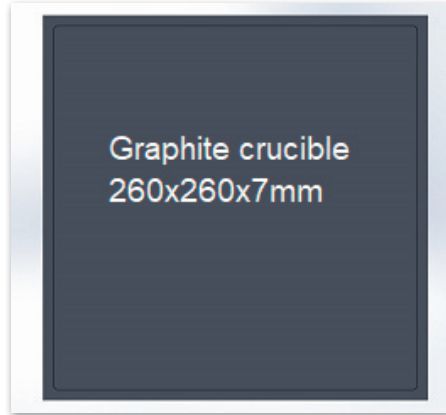

Standard Graphite crucible

Specification

Max. part size	300 x 300 x 40 mm
Chamber material	Aluminium (optional quartz chamber)
Chamber height	40 mm
Part holder	Quartz glass holder with Graphite susceptor (160 x 160 mm)
Vacuum capability	Up to 10 ⁻⁶ hPa (RSO-300-HV)
Process chamber size	309 x 319 x 40 mm (W x D x H)
Temperature max.	650 °C
Temp. uniformity	≤ 1 % of set temperature
Heating	Bottom heating with Infrared lamps
Ramp up rate	Up to 10 K/sec
Ramp down rate	T= 650 °C > 400 °C: 200 K/min, T= 400 °C > 100 °C: 30 K/min
Flow Controller	Mass Flow Controller (Nitrogen 5 nlm= norm liter per minute)
Controller	SIMATIC® Control, 50 programs with 50 steps each
Chamber cooling	Water cooled
Substrate Cooling	By Nitrogen Gas

Technical Data

Dimension oven	505 mm x 505 (700) mm x 570 mm (W x D x H)
Weight	55 kg
Electrical connection	3 x 400 V, 3P, +N+PE, 11 kW or 3 x 208 V, 3P+PE, 10 kW

Options:

FA I	Formic Acid Module - with Mass Flow Controller (external module - able for later retrofit)
FA II	Formic Acid Option with internal gas line and Mass Flow Controller
FA III	Formic Acid Option , the gas line is shared with the standard nitrogen Mass Flow Controller
FA-IV	Integrated formic acid module with separate MFC for carrier gas (N ₂) with automatic refilling
FA-T	Trap for formic acid vapor (for pump protection)
FT	Flux trap (for pump protection)
IL	Interlock mechanism to prevent unintentional opening of the chamber during process
MFC	Additional process gas line with Mass Flow Controller (max. 3 add) *
MM	Moisture Analyser to measure moisture residues in the chamber
OxAtAn	Oxygen Analyser to measure Oxygen residues (not in combination with Hydrogen Option)
PT	Additional 3 colors pat light
SW	Switchbox for chiller and/or vacuum pump
TC	add. Thermocouple to measure on device (plugged in chamber, (max. 3)
VAC I	Basic Vacuum up to 3 hPa, Vacuum sensor, vacuum valve DN16 , ball check valve
VAC II	Comfort Vacuum up to 10exp-3 hPa, Pirani Sensor, vacuum valve DN16, ball check valve
RSO-CAB	Oven integrated as floor model into a cabinet with Uni. Heat Exchanger
RSO-300-QC	Quartz chamber
RSO-300-QC-HV	Quartz chamber for high vacuum option
RSO-300-3star	3-star Quartz holder for 100 mm, 150 mm, 200 mm or 300 mm wafer size
RSO-400-4star	4-star Quartz holder with 4 arms

Accessories

We offer a lot of different kind of closed loop water coolers and different pumps from e.g. Pfeiffer, Edwards, Leybold, Agilent. We recommend the correct configuration for your system.

